

HD29050

Dual Differential Line Drivers/Receivers With 3 State Outputs

REJ03D0304-0300Z
 (Previous ADE-205-034A (Z))
 Rev.3.00
 Jul.16.2004

Description

The HD29050 features differential line drivers/receivers with three state output designed to meet the spec of EIA RS-422A and 423A. Each device has two drivers/receivers in a 16 pin package.

The device becomes in enable state when active high for a driver and active low for a receiver.

Features

Driver

- Built in current restriction when short circuit
- Power up/down protection.
- High output current $I_{OH} = -40 \text{ mA}$
 $I_{OL} = 40 \text{ mA}$

Receiver

- Input hysteresis (Typ. 50 mV)
- In phase input voltage $\pm 200 \text{ mV}$ of input sensitivity in the range -7 to $+12 \text{ V}$.
- Ordering Information

Part Name	Package Type	Package Code	Package Abbreviation	Taping Abbreviation (Quantity)
HD29050P	DILP-16 pin	DP-16E, -16FV	P	—

Pin Arrangement

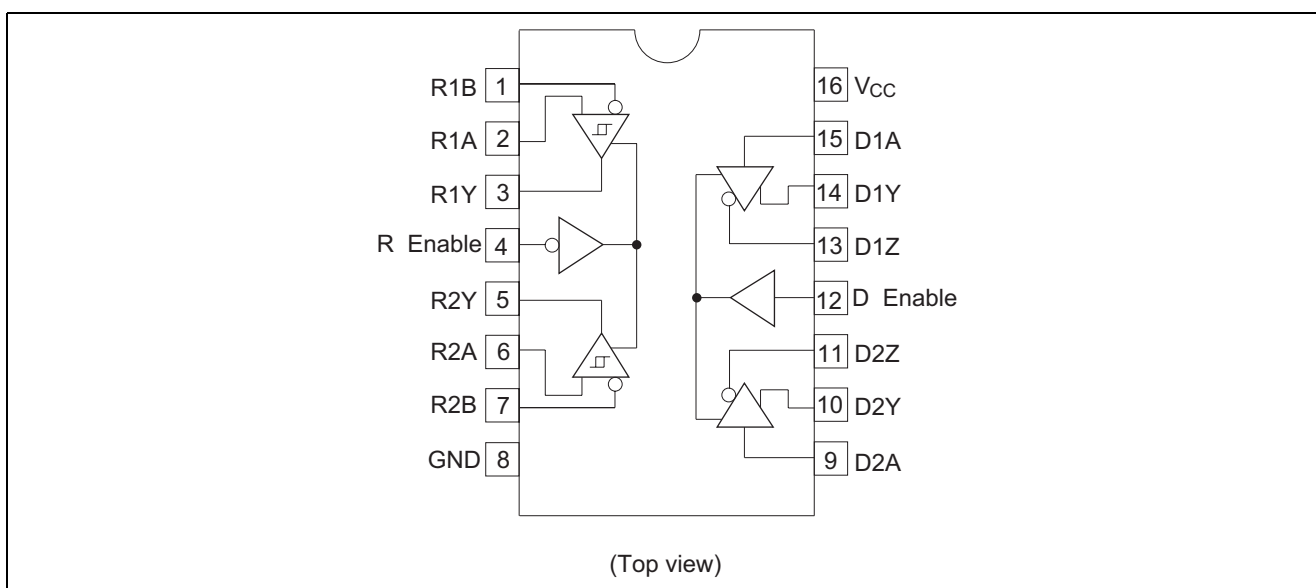

Function Table

Drivers				Receivers		
Input A	Enable	Output Y	Output Z	Differential Input A – B	Enable	Output Y
L	H	L	H	$V_{ID} \geq 0.2 \text{ V}$	L	H
H	H	H	L	$-0.2 \text{ V} < V_{ID} < 0.2 \text{ V}$	L	?
X	L	Z	Z	$V_{ID} \leq -0.2 \text{ V}$	H	Z
				X	H	Z

H : High level

L : Low level

Z : High impedance

X : Immaterial

? : Irrelevant

Absolute Maximum Ratings

Item	Symbol	Ratings	Unit
Supply Voltage*1	V_{CC}	7	V
Input Voltage A, B*3	V_{IN}	± 25	V
Differential Input Voltage*2*3	V_{ID}	± 25	V
Output Current*3	I_O	50	mA
Enable Input Voltage	V_{IE}	5.5	V
Input Voltage*4	V_{IN}	5.5	V
Output Applied Voltage*4*5	V_O	-1.0 to 7.0	V
Operating Temperature Range	T_{opr}	0 to 70	°C
Storage Temperature Range	T_{stg}	-65 to 150	°C

Notes: 1. All voltage values except for differential input voltage are with respect to network ground terminal.

2. Differential input voltage is measured at the noninverting input with respect to the corresponding inverting input.

3. Only receiver

4. Only driver

5. Z state

6. The absolute maximum ratings are values which must not individually be exceeded, and furthermore, no two of which may be realized at the same time.

Recommended Operating Conditions

Item	Symbol	Min	Typ	Max	Unit
Supply Voltage	V_{CC}	4.75	5.0	5.25	V
In Phase Input Voltage*1	V_{IC}	-7.0	—	12	V
Differential Input Voltage*1	V_{ID}	-6.0	—	6.0	V
Enable Input Voltage	V_{IE}	0	—	5.25	V
Input Voltage*2	V_{IN}	0	—	5.25	V
Operating Temperature	T_{opr}	0	25	70	°C

Notes: 1. Only receiver

2. Only driver

Electrical Characteristics (Ta = 0 to +70°C)

Driver

Item	Symbol	Min	Typ	Max	Unit	Conditions
Input Voltage	V_{IHD}	2.0	—	—	V	
	V_{ILD}	—	—	0.8	V	
Input Clamp Voltage	V_{IKD}	—	—	-1.5	V	$V_{CC} = 4.75\text{ V}$, $I_I = -18\text{ mA}$
Output Voltage	V_{OHD}	2.5	—	—	V	$V_{CC} = 4.75\text{ V}$, $I_{OH} = -20\text{ mA}$
		2.4	—	—	V	$V_{CC} = 4.75\text{ V}$, $I_{OH} = -40\text{ mA}$
	V_{OLD}	—	—	0.45	V	$V_{CC} = 4.75\text{ V}$, $I_{OL} = 20\text{ mA}$
		—	—	0.5	V	$V_{CC} = 4.75\text{ V}$, $I_{OL} = 40\text{ mA}$
Output Leak Current	I_{OZD}	-100	—	100	μA	$V_{CC} = 5.25\text{ V}$, $V_O = 0.5\text{ V}$, Enable = 0.8 V
		-100	—	100	μA	$V_{CC} = 5.25\text{ V}$, $V_O = 2.7\text{ V}$, Enable = 0.8 V
	$I_{O(Off)}$	—	—	-100	μA	$V_{CC} = 0\text{ V}$, $V_O = -0.25\text{ V}$
		—	—	-100	μA	$V_{CC} = 0\text{ V}$, $V_O = 6.0\text{ V}$
Input Current	I_{ID}	—	—	100	μA	$V_{CC} = 5.25\text{ V}$, $V_I = 5.25\text{ V}$
	I_{IHD}	—	—	20	μA	$V_{CC} = 5.25\text{ V}$, $V_I = 2.7\text{ V}$
	I_{ILD}	—	—	-360	μA	$V_{CC} = 5.25\text{ V}$, $V_I = 0.4\text{ V}$
Differential Output Voltage	$\Delta V_{OC} $	—	—	0.4	V	
	$ V_{OD2} $	2.0	—	—	V	
	$\Delta V_{OD} $	—	—	0.4	V	
Short Circuit Output Current*1	I_{OSD}	-30	—	-150	mA	$V_{CC} = 5.25\text{ V}$, $V_O = 0\text{ V}$

Electrical Characteristics (Ta = 0 to +70°C)

Receiver

Item	Symbol	Min	Typ	Max	Unit	Conditions
Differential Input Threshold Voltage*2	V _{THR}	—	—	0.2	V	V _O ≥ 2.7 V -7.0 V < V _{IC} < 12 V
		-0.2	—	—	V	V _O ≤ 0.45 V -7.0 V < V _{IC} < 12 V
Input Current	I _{IBR}	—	—	1.0	mA	V _{IN} ≤ V _{I2} , 0 V, V _{CC} ≤ 5.25 V
		—	—	-0.8	mA	V _{IN} ≤ V _{I7} , 0 V, V _{CC} ≤ 5.25 V
Output Voltage	V _{OHR}	2.7	—	—	V	V _{CC} = 4.75 V, I _O = -400 mA V _{ID} = 0.4 V, -7.0 V < V _{ICM} < 12 V
	V _{OLR}	—	—	0.45	V	V _{CC} = 4.75 V, I _O = 8.0 mA V _{ID} = -0.4 V, -7.0 V < V _{ICM} < 12 V
Output Leak Current	I _{OZR}	-100	—	100	mA	V _{CC} = 5.25 V, V _O = 0.4 V V _{ID} = 3.0 V, Enable = 2.0 V
		-100	—	100	mA	V _{CC} = 5.25 V, V _O = 2.4 V V _{ID} = -3.0 V, Enable = 2.0 V
Short Circuit Output Current*1	I _{OSR}	-15	—	-85	mA	V _{CC} = 5.25 V, V _O = 0 V V _{ID} = 3.0 V
Input Voltage	V _{IHE}	2.0	—	—	V	
	V _{ILE}	—	—	0.8	V	
Input Current	I _{IIE}	—	—	-100	μA	V _{CC} = 5.25 V, V _{IL} = 0.4 V
	I _{IHE}	—	—	20	μA	V _{CC} = 5.25 V, V _{IH} = 2.7 V
	I _{IE}	—	—	100	μA	V _{CC} = 5.25 V, V _{IH} = 5.25 V
Input Clamp Voltage	V _{IKE}	—	—	-1.5	V	V _{CC} = 4.75, I _I = -18 mA

Supply

Item	Symbol	Min	Typ	Max	Unit	Conditions
Supply Current	I _{CC}	—	55*3	80	mA	V _{CC} = 5.25 V

- Notes: 1. Not more than one output should be shorted at a time, and duration of the short circuit should not exceed one second.
 2. In this table, only the threshold voltage is expressed in algebra.
 3. All typical values are at V_{CC} = 5 V, Ta = 25°C.

Switching Characteristics ($T_a = 25^\circ\text{C}$, $V_{CC} = 5\text{ V}$)**Driver**

Item	Symbol	Min	Typ	Max	Unit	Conditions
Propagation Delay Time	t_{PLHD}	—	—	20	ns	$C_L = 30\text{ pF}$, $R_L = 75\ \Omega$ to GND $R_L = 180\ \Omega$ to V_{CC}
	t_{PHLD}	—	—	20	ns	$C_L = 30\text{ pF}$, $R_L = 75\ \Omega$ to GND $R_L = 180\ \Omega$ to V_{CC}
Propagation Delay Time Difference	t_{SKD}^{*1}	—	—	4	ns	$C_L = 30\text{ pF}$, $R_L = 75\ \Omega$ to GND $R_L = 180\ \Omega$ to V_{CC}
Output Enable Time	t_{ZHD}	—	—	20	ns	$C_L = 30\text{ pF}$, $R_L = 75\ \Omega$ to GND
	t_{ZLD}	—	—	35	ns	$C_L = 30\text{ pF}$, $R_L = 180\ \Omega$ to V_{CC}
Output Disable Time	t_{HZD}	—	—	20	ns	$C_L = 10\text{ pF}$, $R_L = 75\ \Omega$ to GND
	t_{LZD}	—	—	25	ns	$C_L = 10\text{ pF}$

Receiver

Item	Symbol	Min	Typ	Max	Unit	Conditions
Propagation Delay Time	t_{PLHR}	—	—	40	ns	$C_L = 15\text{ pF}$
	t_{PHLR}	—	—	40	ns	$C_L = 15\text{ pF}$
Output Enable Time	t_{ZHR}	—	—	20	ns	$C_L = 15\text{ pF}$, $R_L = 5\text{ K}\Omega$ to GND
	t_{ZLR}	—	—	25	ns	$C_L = 15\text{ pF}$, $R_L = 2\text{ K}\Omega$ to V_{CC}
Output Disable Time	t_{HZR}	—	—	30	ns	$C_L = 15\text{ pF}$, $R_L = 5\text{ K}\Omega$ to GND $R_L = 2\text{ K}\Omega$ to V_{CC}
	t_{LZR}	—	—	30	ns	

Note: 1. $t_{SKD} = |t_{PLHD} - t_{PHLD}|$

DC Test ($|V_{OD2}|$, $\Delta |V_{OD}|$, V_{OC} , $\Delta |V_{OC}|$)

$|V_{OD2}|$, $\Delta |V_{OD}|$ Test

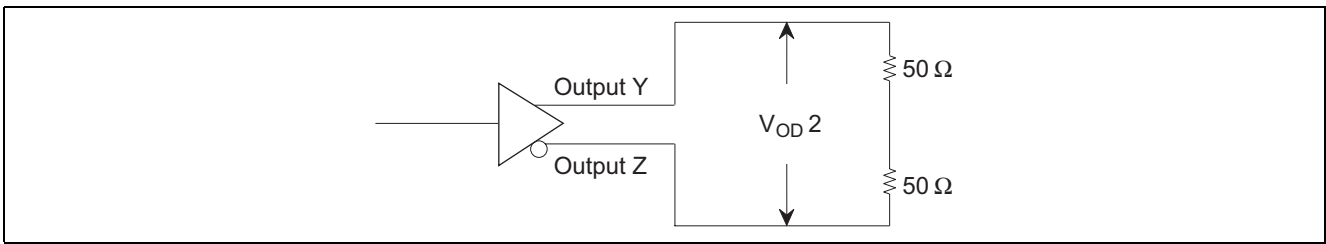

V_{OC} , $\Delta |V_{OC}|$ Test

Note: $|V_{OD}|$ and $\Delta |V_{OC}|$ indicate the differences of voltage from the former states when Y and Z outputs are inverted.

$$\Delta |V_{OD}| = ||V_{OD2}| - |V_{OD2}||$$

$$\Delta |V_{OC}| = |V_{OC} - V_{OC}|$$

1. t_{PLHD} , t_{PHLD}

Test circuit

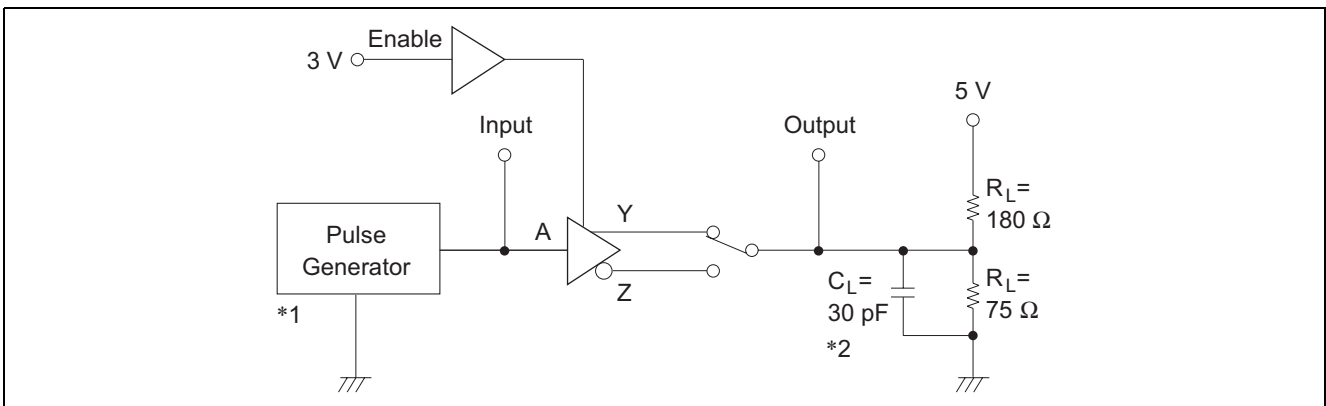

Waveforms

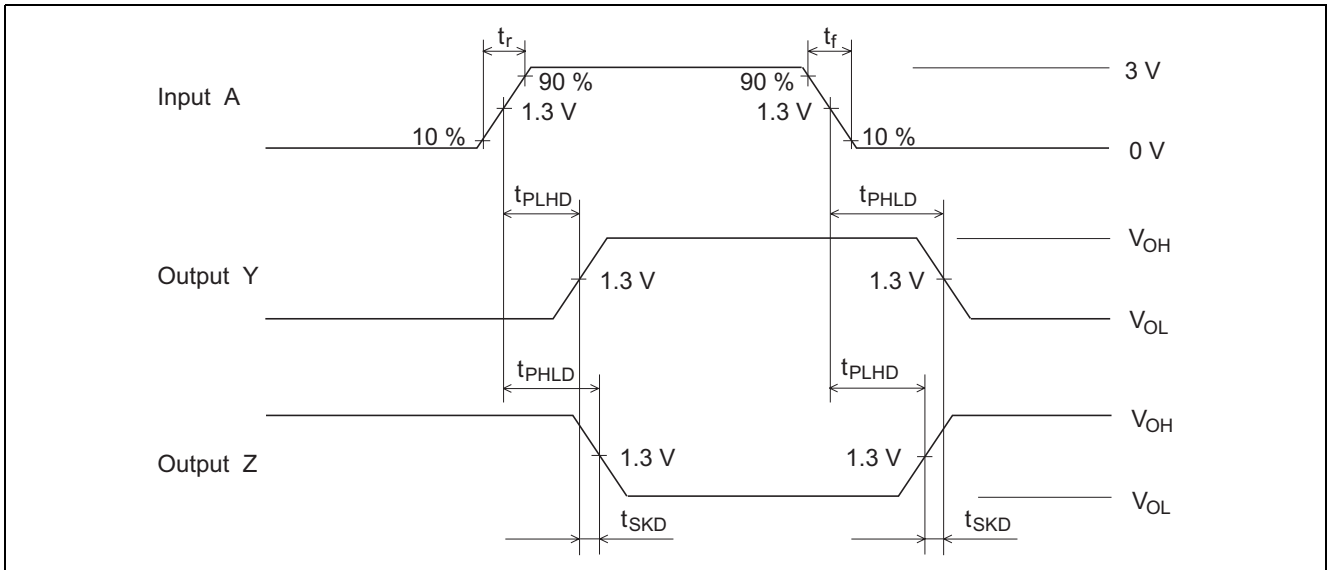

2. t_{zHD} , t_{zLD} , t_{HzD} , t_{LzD}

Test circuit

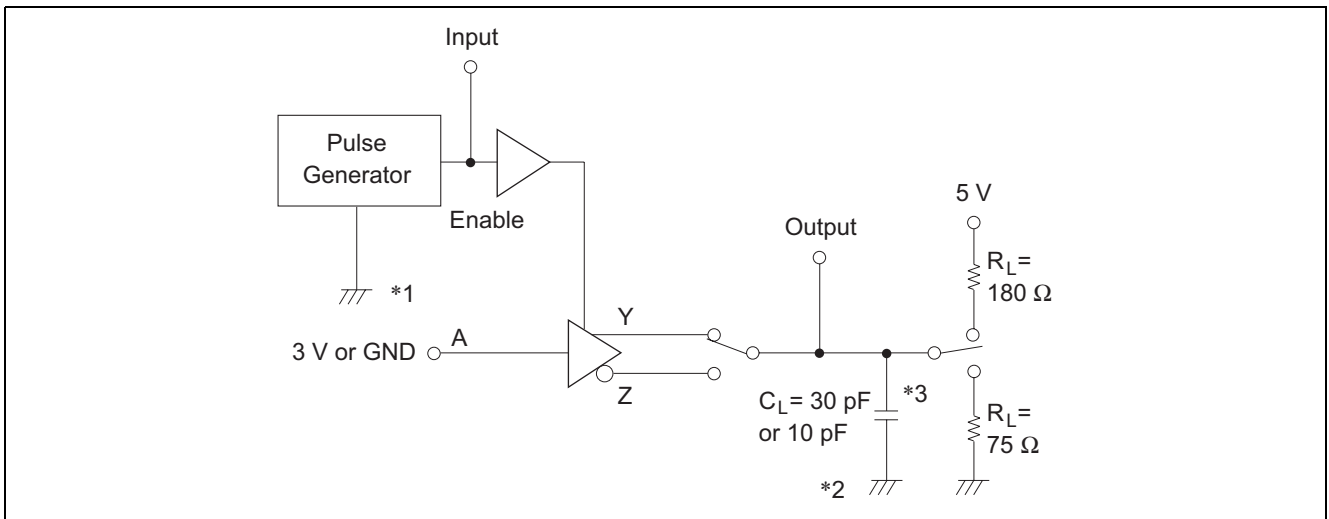

Waveforms

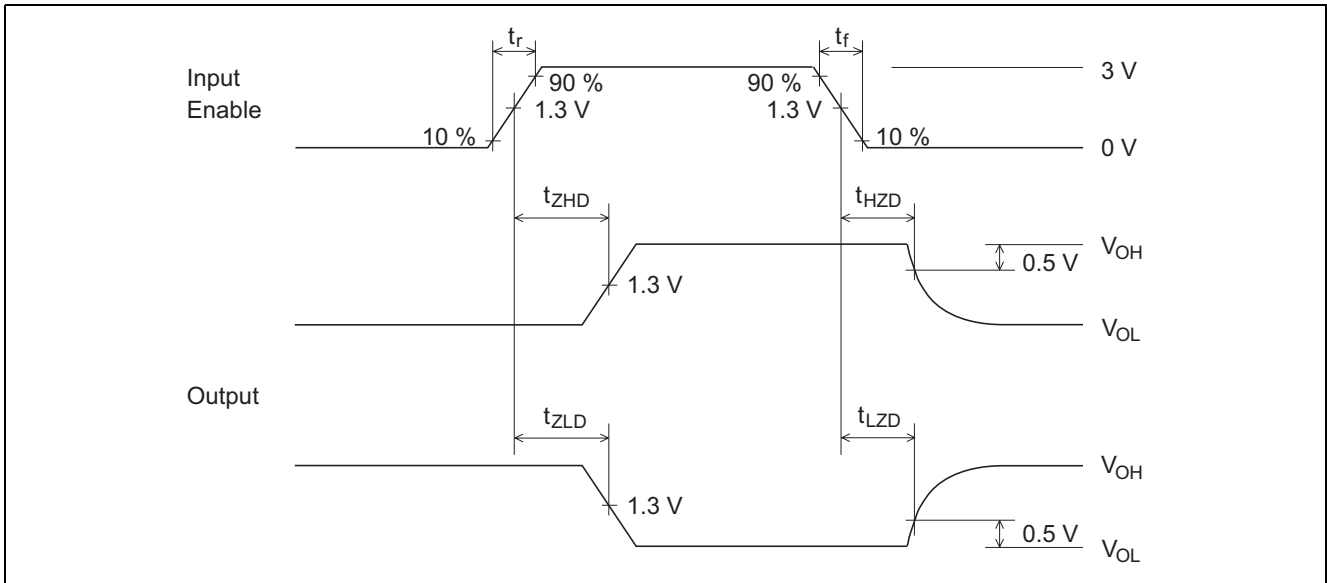

3. t_{PLHR} , t_{PHLR}

Test circuit

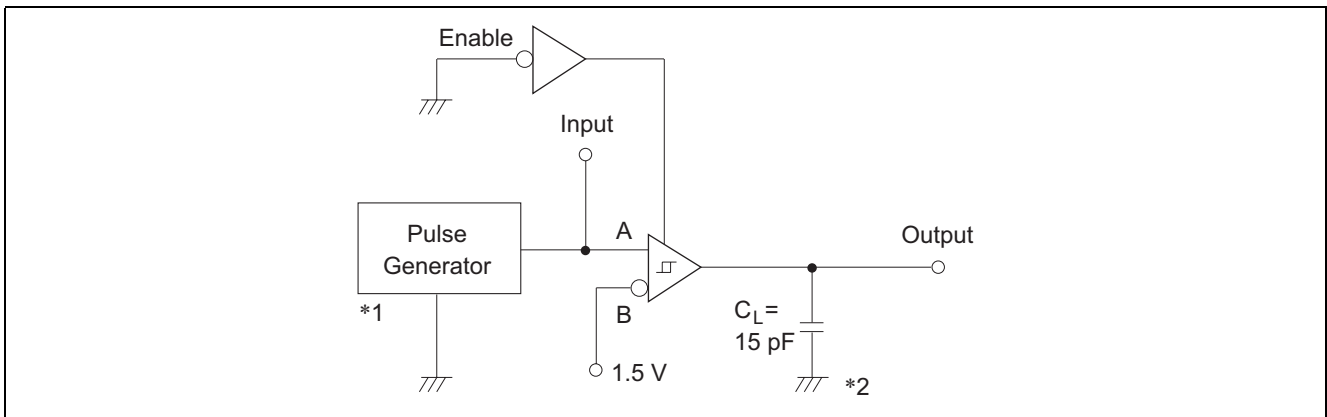

Waveforms

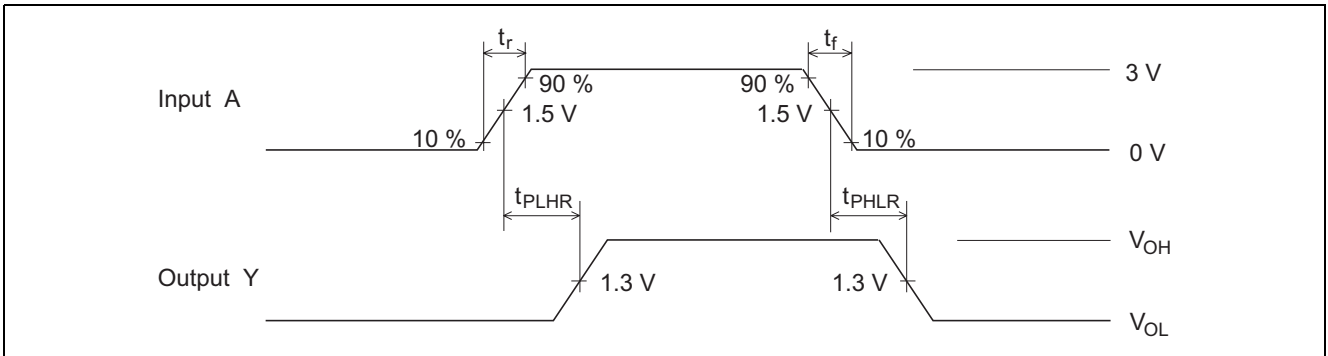

4. t_{ZHR} , t_{ZLR} , t_{HZR} , t_{LZR}

Test circuit

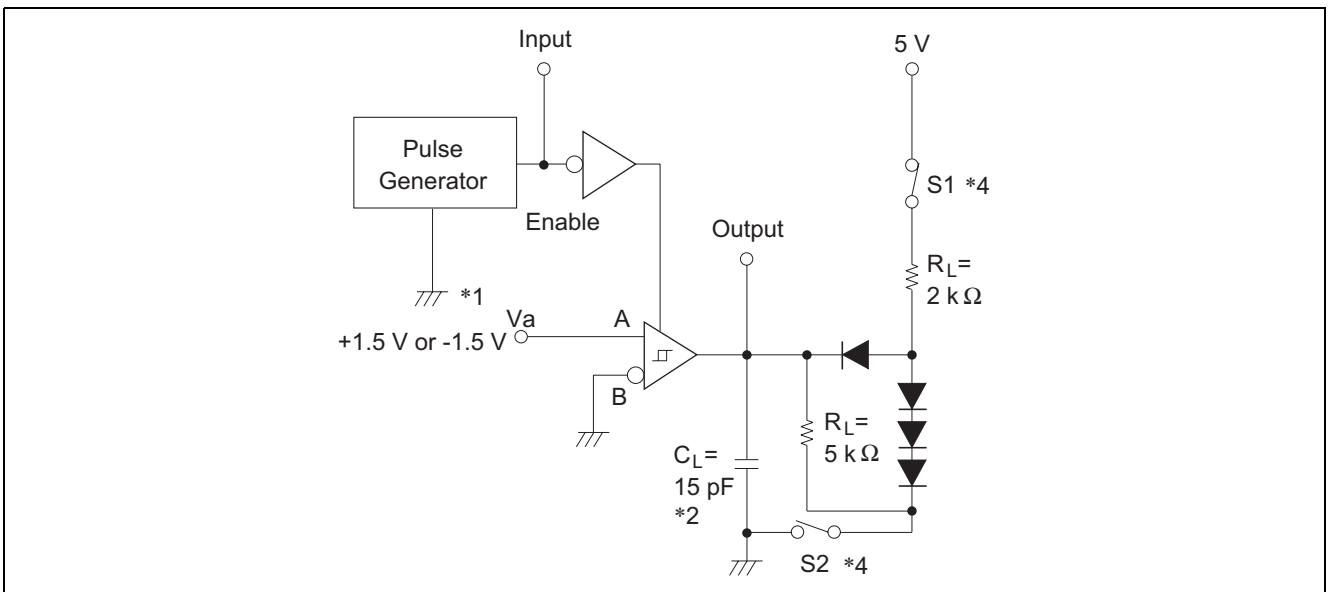

Waveforms

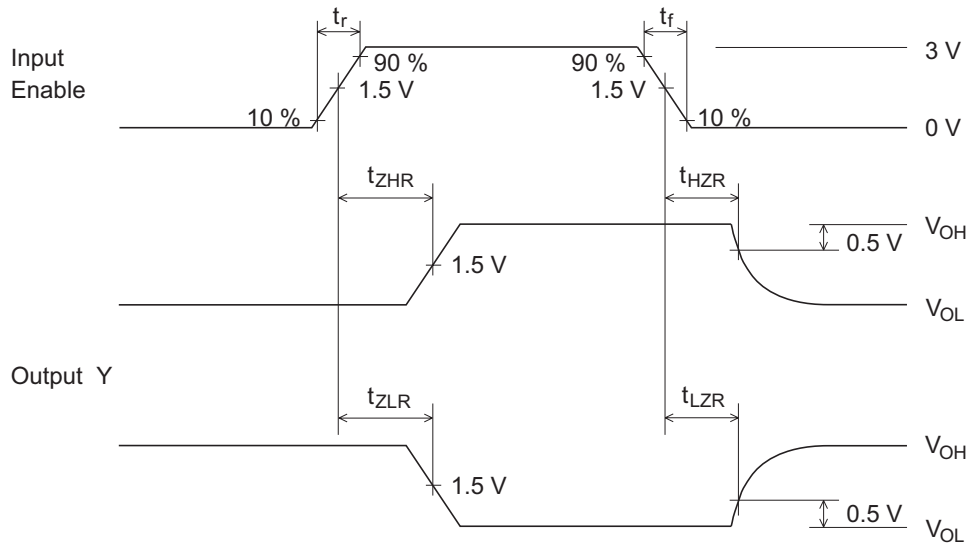

- Notes:
1. The pulse generator has the following characteristics:
 PRR = 1 MHz, 50% duty cycle, $t_r = t_f = 6.0$ ns.
 2. C_L includes probe and jig capacitance.
 3. 75 Ω connected between the pin and GND at t_{ZHD} t_{HZD} test.
 180 Ω connected between the pin and GND at t_{ZHD} t_{HZD} test.
 4. At t_{HZR} , t_{LZR} test, S_1 and S_2 are closed.
 At t_{ZHR} test, S_1 is open and S_2 is closed.
 At t_{ZLR} test, S_1 is closed and S_2 is open.

Main Characteristics

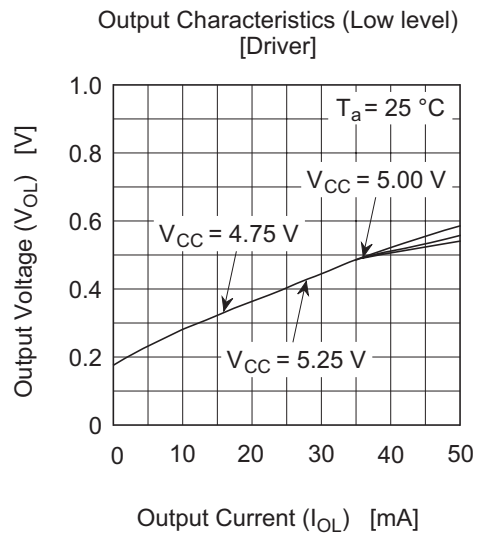
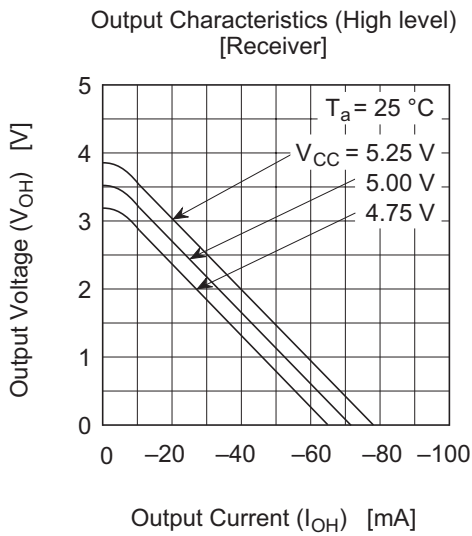
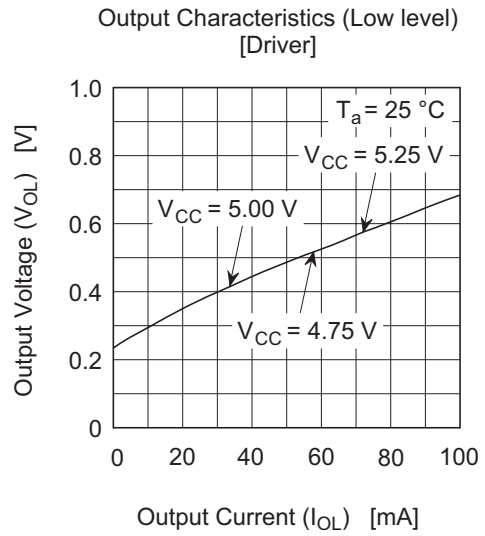
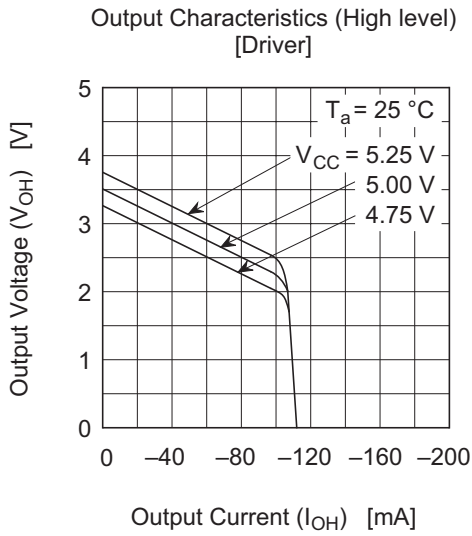

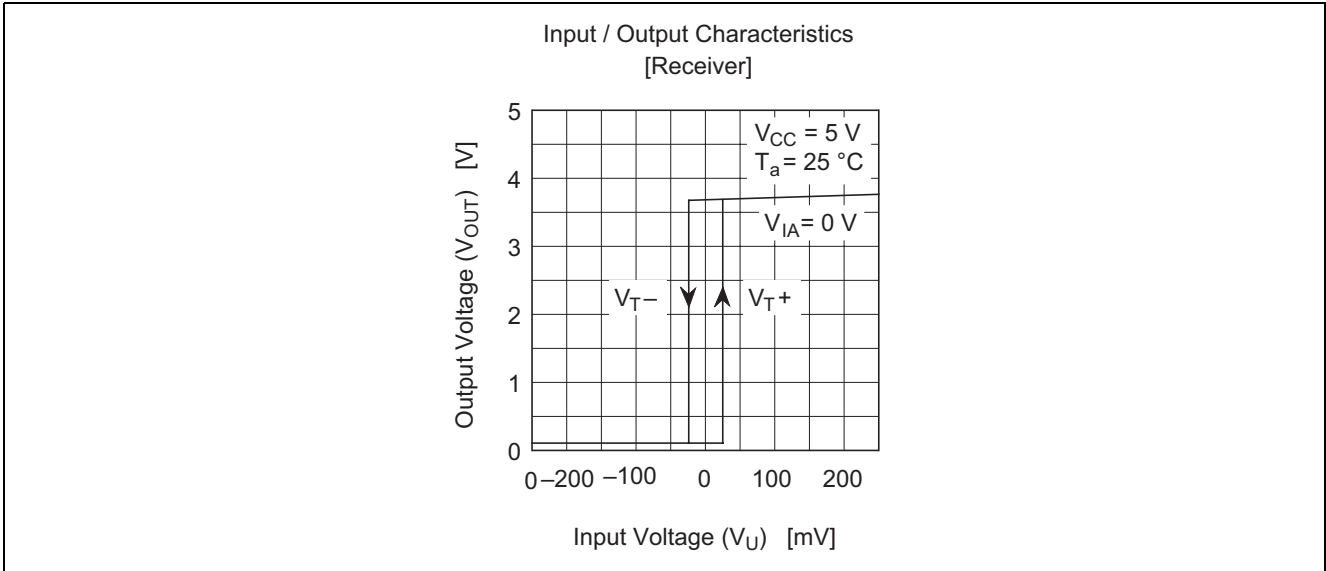

Package Dimensions

As of January, 2003
Unit: mm

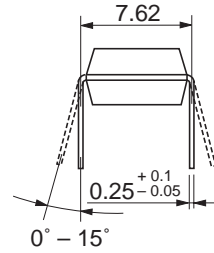
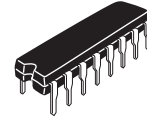
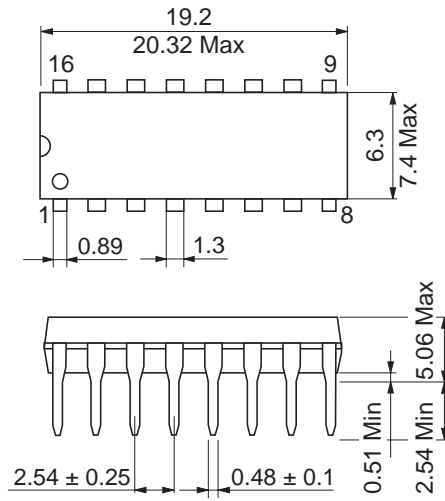

Package Code	DP-16E
JEDEC	Conforms
JEITA	Conforms
Mass (reference value)	1.05 g

Unit: mm

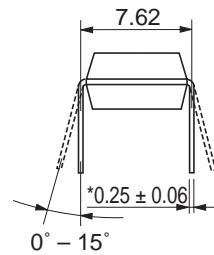
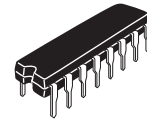
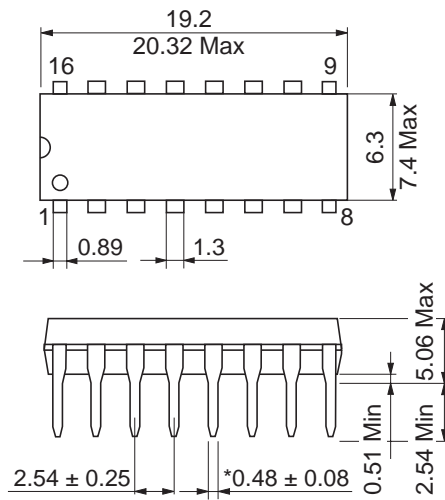

*Ni/Pd/AU Plating

Package Code	DP-16FV
JEDEC	Conforms
JEITA	Conforms
Mass (reference value)	1.05 g

Renesas Technology Corp. Sales Strategic Planning Div. Nippon Bldg., 2-6-2, Ohte-machi, Chiyoda-ku, Tokyo 100-0004, Japan

Keep safety first in your circuit designs!

1. Renesas Technology Corp. puts the maximum effort into making semiconductor products better and more reliable, but there is always the possibility that trouble may occur with them. Trouble with semiconductors may lead to personal injury, fire or property damage. Remember to give due consideration to safety when making your circuit designs, with appropriate measures such as (i) placement of substitutive, auxiliary circuits, (ii) use of nonflammable material or (iii) prevention against any malfunction or mishap.

Notes regarding these materials

1. These materials are intended as a reference to assist our customers in the selection of the Renesas Technology Corp. product best suited to the customer's application; they do not convey any license under any intellectual property rights, or any other rights, belonging to Renesas Technology Corp. or a third party.
 2. Renesas Technology Corp. assumes no responsibility for any damage, or infringement of any third-party's rights, originating in the use of any product data, diagrams, charts, programs, algorithms, or circuit application examples contained in these materials.
 3. All information contained in these materials, including product data, diagrams, charts, programs and algorithms represents information on products at the time of publication of these materials, and are subject to change by Renesas Technology Corp. without notice due to product improvements or other reasons. It is therefore recommended that customers contact Renesas Technology Corp. or an authorized Renesas Technology Corp. product distributor for the latest product information before purchasing a product listed herein.
The information described here may contain technical inaccuracies or typographical errors.
Renesas Technology Corp. assumes no responsibility for any damage, liability, or other loss rising from these inaccuracies or errors.
Please also pay attention to information published by Renesas Technology Corp. by various means, including the Renesas Technology Corp. Semiconductor home page (<http://www.renesas.com>).
 4. When using any or all of the information contained in these materials, including product data, diagrams, charts, programs, and algorithms, please be sure to evaluate all information as a total system before making a final decision on the applicability of the information and products. Renesas Technology Corp. assumes no responsibility for any damage, liability or other loss resulting from the information contained herein.
 5. Renesas Technology Corp. semiconductors are not designed or manufactured for use in a device or system that is used under circumstances in which human life is potentially at stake. Please contact Renesas Technology Corp. or an authorized Renesas Technology Corp. product distributor when considering the use of a product contained herein for any specific purposes, such as apparatus or systems for transportation, vehicular, medical, aerospace, nuclear, or undersea repeater use.
 6. The prior written approval of Renesas Technology Corp. is necessary to reprint or reproduce in whole or in part these materials.
 7. If these products or technologies are subject to the Japanese export control restrictions, they must be exported under a license from the Japanese government and cannot be imported into a country other than the approved destination.
Any diversion or reexport contrary to the export control laws and regulations of Japan and/or the country of destination is prohibited.
 8. Please contact Renesas Technology Corp. for further details on these materials or the products contained therein.
-



RENESAS SALES OFFICES

<http://www.renesas.com>

Renesas Technology America, Inc.

450 Holger Way, San Jose, CA 95134-1368, U.S.A
Tel: <1> (408) 382-7500 Fax: <1> (408) 382-7501

Renesas Technology Europe Limited.

Dukes Meadow, Millboard Road, Bourne End, Buckinghamshire, SL8 5FH, United Kingdom
Tel: <44> (1628) 585 100, Fax: <44> (1628) 585 900

Renesas Technology Europe GmbH

Dornacher Str. 3, D-85622 Feldkirchen, Germany
Tel: <49> (89) 380 70 0, Fax: <49> (89) 929 30 11

Renesas Technology Hong Kong Ltd.

7/F., North Tower, World Finance Centre, Harbour City, Canton Road, Hong Kong
Tel: <852> 2265-6688, Fax: <852> 2375-6836

Renesas Technology Taiwan Co., Ltd.

FL 10, #99, Fu-Hsing N. Rd., Taipei, Taiwan
Tel: <886> (2) 2715-2888, Fax: <886> (2) 2713-2999

Renesas Technology (Shanghai) Co., Ltd.

26/F., Ruijin Building, No.205 Maoming Road (S), Shanghai 200020, China
Tel: <86> (21) 6472-1001, Fax: <86> (21) 6415-2952

Renesas Technology Singapore Pte. Ltd.

1, Harbour Front Avenue, #06-10, Keppel Bay Tower, Singapore 098632
Tel: <65> 6213-0200, Fax: <65> 6278-8001