

TOSHIBA

INTEGRATED GTR MODULE

MIG50J901H

Unit in mm

High Power Switching Applications

Motor Control Applications

- Integrates Inverter, Converter and Brake Power Circuits in One Package.
- Output (Inverter Stage)
 - : 3 ϕ 50A/600V High Speed Type IGBT
 - $V_{CE(sat)}$ = 4.0V (Max.)
 - t_f = 0.30 μ s (Max.)
 - t_{rr} = 0.15 μ s (Max.)
- Input (Converter Stage)
 - : 3 ϕ 30A/800V Silicon Rectifier
 - V_F = 1.20V (Max.)
- Brake Stage
 - : 25A/600V IGBT & 15A/600V FRD
- The Electrodes are Isolated from Case.

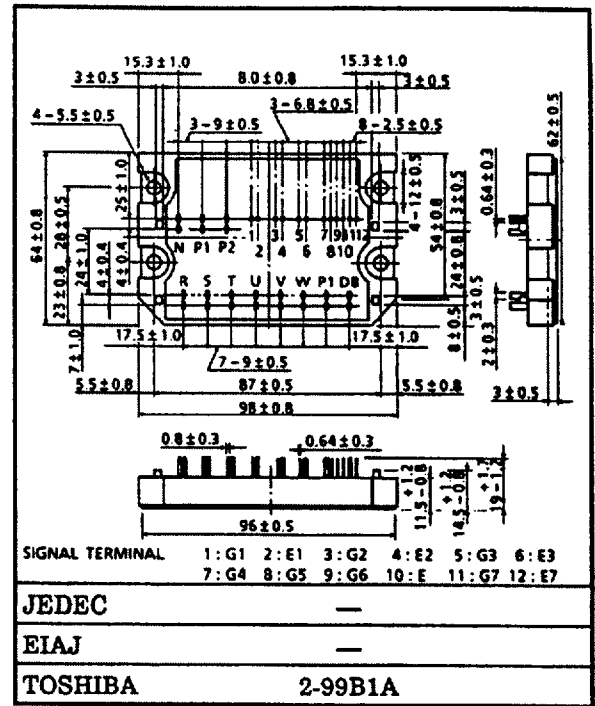

Weight : 245g

Equivalent Circuit

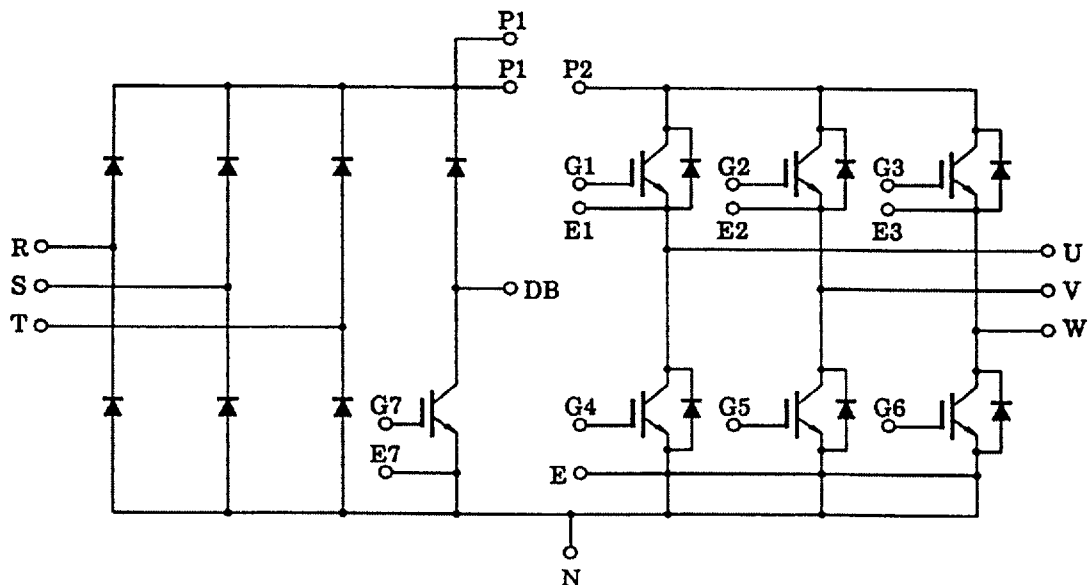

The information contained here is subject to change without notice.

The information contained herein is presented only as guide for the applications of our products. No responsibility is assumed by TOSHIBA for any infringements of patents or other rights of the third parties which may result from its use. No license is granted by implication or otherwise under any patent or patent rights of TOSHIBA or others. These TOSHIBA products are intended for usage in general electronic equipments (office equipment, communication equipment, measuring equipment, domestic electrification, etc.) Please make sure that you consult with us before you use these TOSHIBA products in equipments which require high quality and/or reliability, and in equipments which could have major impact to the welfare of human life (atomic energy control, spaceship, traffic signal, combustion control, all types of safety devices, etc.). TOSHIBA cannot accept liability to any damage which may occur in case these TOSHIBA products were used in the mentioned equipments without prior consultation with TOSHIBA.

MIG50J901H

Maximum Ratings (Ta = 25°C)

| STAGE | | CHARACTERISTIC | | SYMBOL | RATINGS | UNIT | |
|---|---|---------------------------------|------------|--------------------|-----------|------|---|
| Inverter | Collector-Emitter Voltage | | | V_{CES} | 600 | V | |
| | Gate-Emitter Voltage | | | V_{GES} | ±20 | V | |
| | Collector Current | DC | | I_C | 50 | A | |
| | | 1ms | | I_{CP} | 100 | | |
| | Forward Current | DC | | I_F | 50 | A | |
| | | 1ms | | I_{FM} | 100 | | |
| Collector Power Dissipation (tc = 25°C) | | | P_C | 125 | W | | |
| Converter | Repetitive Peak Reverse Voltage | | | V_{RRM} | 800 | V | |
| | Average Output Rectified Current | | | I_O | 30 | A | |
| | Peak One Cycle Surge Forward Current (50Hz, Non-Repetitive) | | | I_{FSM} | 400 | A | |
| Brake | IGBT | Collector-Emitter Voltage | | | V_{CES} | 600 | V |
| | | Gate-Emitter Voltage | | | V_{GES} | ±20 | V |
| | | Collector Current | DC | | I_C | 25 | A |
| | | | 1ms | | I_{CP} | 50 | |
| | Collector Power Dissipation (Tc = 25°C) | | | P_C | 100 | W | |
| | FRD | Repetitive Peak Reverse Voltage | | | V_{RRM} | 600 | V |
| | | Forward Current | DC | | I_F | 15 | A |
| | | | 1ms | | I_{FM} | 30 | |
| Junction Temperature | | | T_j | 150 | °C | | |
| Storage Temperature Range | | | T_{stg} | -40 ~ 125 | °C | | |
| Isolation Voltage | | | V_{isol} | 2500 (AC 1 minute) | V | | |
| Screw Torque | | | — | 3 | N•m | | |

Electrical Characteristics (Ta = 25°C)

a. Inverter Stage

| CHARACTERISTIC | | SYMBOL | TEST CONDITION | MIN. | TYP. | MX. | UNIT |
|--------------------------------------|---------------------|----------------|--|------|------|----------|---------------|
| Gate Leakage Current | | I_{GES} | $V_{GE} = \pm 20V, V_{CE} = 0$ | – | – | ± 20 | μA |
| Collector Cut-off Current | | I_{CES} | $V_{CE} = 600V, V_{GE} = 0$ | – | – | 1.0 | mA |
| Gate-Emitter Cut-off Voltage | | $V_{GE (off)}$ | $V_{CE} = 5V, I_C = 50mA$ | 3.0 | – | 6.0 | V |
| Collector-Emitter Saturation Voltage | | $V_{CE (sat)}$ | $I_C = 50A, V_{GE} = 15V$ | – | 3.0 | 4.0 | V |
| Input Capacitance | | C_{ies} | $V_{CE} = 10V, V_{GE} = 0$ $f = 1MHz$ | – | 3100 | – | pF |
| Switching Time | Turn-on Delay Time | $t_{d(on)}$ | Inductive Load $V_{CC} = 300V$ $I_C = 50A$ $V_{GE} = \pm 15V$ $R_G = 51\Omega$ (Note 1) | – | 0.08 | 0.16 | μs |
| | Rise Time | t_r | | – | 0.12 | 0.24 | |
| | Turn-on Time | t_{on} | | – | 0.40 | 0.80 | |
| | Turn-off Delay Time | $t_{d(off)}$ | | – | 0.30 | 0.60 | |
| | Fall Time | t_f | | – | 0.15 | 0.30 | |
| | Turn-off Time | t_{off} | | – | 0.60 | 1.00 | |
| Forward Voltage | | V_F | $I_F = 50A, V_{GE} = 0$ | – | 1.7 | 2.5 | V |
| Reverse Recovery Time | | t_{rr} | $I_F = 50A, V_{GE} = -10V$ $di/dt = 100A/\mu s$ | – | 0.08 | 0.15 | μs |
| Thermal Resistance | | $R_{th(j-c)}$ | Transistor | – | – | 1.0 | $^{\circ}C/W$ |
| | | | Diode | – | – | 1.56 | |

b. Converter Stage

| CHARACTERISTIC | SYMBOL | TEST CONDITION | MIN. | TYP. | MX. | UNIT |
|--------------------------------------|---------------|---------------------|------|------|------|---------------|
| Repetitive Peak Reverse Current | I_{RRM} | $V_{RRM} = 800V$ | – | – | 50 | μA |
| Peak Forward Voltage | V_{FM} | $I_{FM} = 30A$ | – | 1.05 | 1.20 | V |
| Peak One Cycle Surge Forward Current | I_{FSM} | 50Hz Sine-half-wave | 400 | – | – | V |
| Thermal Resistance | $R_{th(j-c)}$ | | – | – | 1.56 | $^{\circ}C/W$ |

MIG50J901H

c. Brake Stage

| CHARACTERISTIC | | SYMBOL | TEST CONDITION | MIN. | TYP. | MX. | UNIT |
|--------------------------------------|---------------------|---------------|---|------|------|-----------|---------------|
| Gate Leakage Current | | I_{GES} | $V_{GE} = \pm 20V, V_{CE} = 0$ | - | - | ± 500 | nA |
| Collector Cut-off Current | | I_{CES} | $V_{CE} = 600V, V_{GE} = 0$ | - | - | 1.0 | mA |
| Repetitive Peak Reverse Current | | I_{RRM} | $V_{RRM} = 600V$ | - | - | 1.0 | mA |
| Gate-Emitter Cut-off Voltage | | $V_{GE(off)}$ | $V_{CE} = 5V, I_C = 25mA$ | 3.0 | - | 6.0 | V |
| Collector-Emitter Saturation Voltage | | $V_{CE(sat)}$ | $I_C = 25A, V_{GE} = 15V$ | - | 3.0 | 4.0 | V |
| Input Capacitance | | C_{ies} | $V_{CE} = 10V, V_{GE} = 0, f = 1MHz$ | - | 2000 | - | pF |
| Switching Time | Turn-on Delay Time | $t_d(on)$ | Inductive Load $V_{CC} = 300V$ $I_C = 25A$ $V_{GE} = \pm 15V$ $R_G = 100\Omega$ (Note 1) | - | 0.08 | 0.16 | μs |
| | Rise Time | t_r | | - | 0.12 | 0.24 | |
| | Turn-on Time | t_{on} | | - | 0.40 | 0.80 | |
| | Turn-off Delay Time | $t_d(off)$ | | - | 0.30 | 0.60 | |
| | Fall Time | t_f | | - | 0.30 | 0.55 | |
| | Turn-off Time | t_{off} | | - | 0.65 | 1.00 | |
| Forward Voltage | | V_F | $I_F = 15A, V_{GE} = 0$ | - | 1.7 | 2.5 | V |
| Thermal Resistance | | $R_{th(j-c)}$ | Transistor | - | - | 1.25 | $^{\circ}C/W$ |
| | | | Diode | - | - | 2.80 | |

Note. 1 Switching Time Test Circuit & Timing Chart

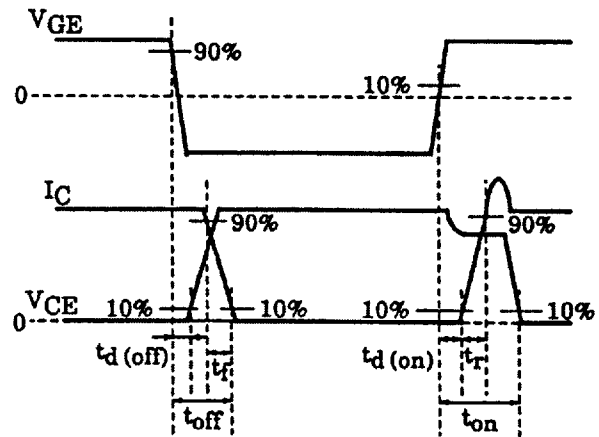
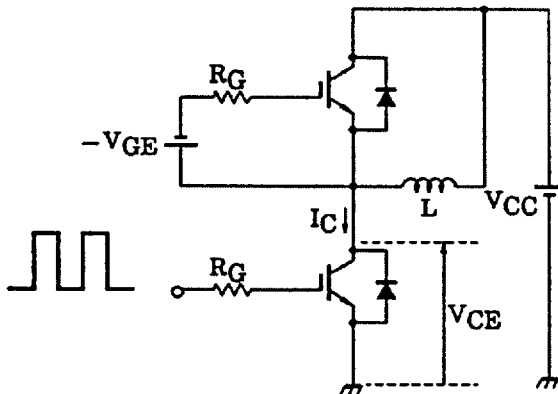

a. Inverter Stage

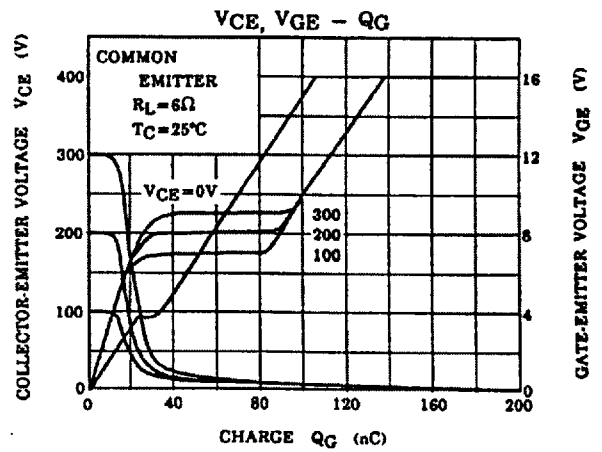
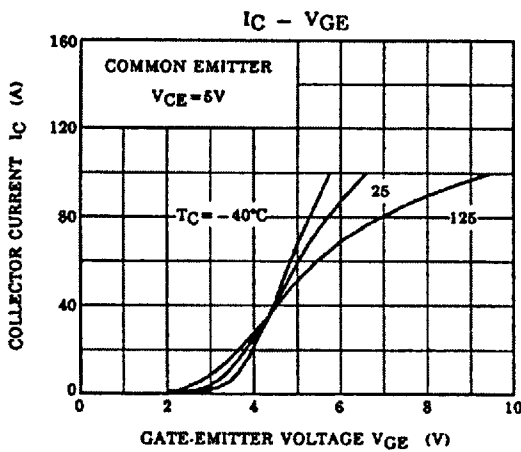
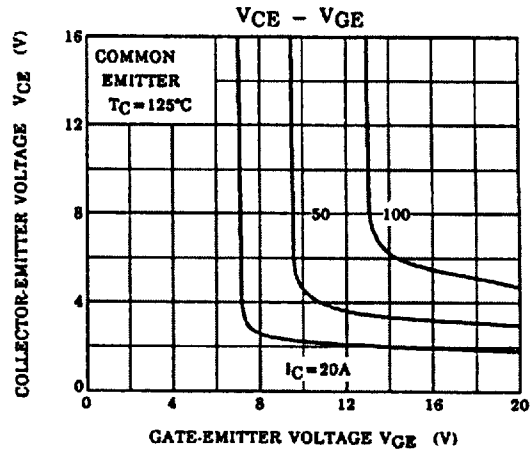
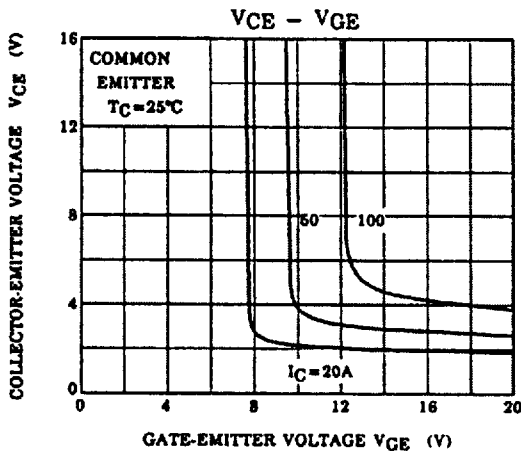
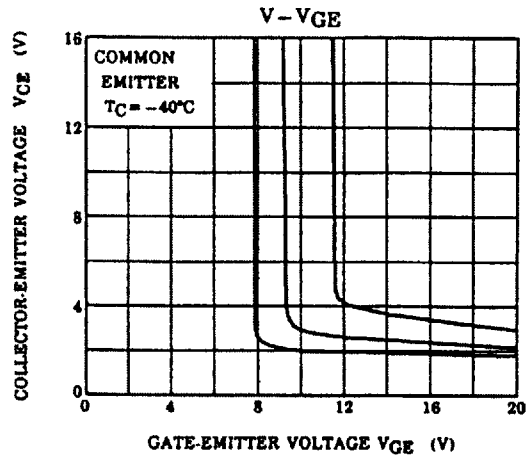
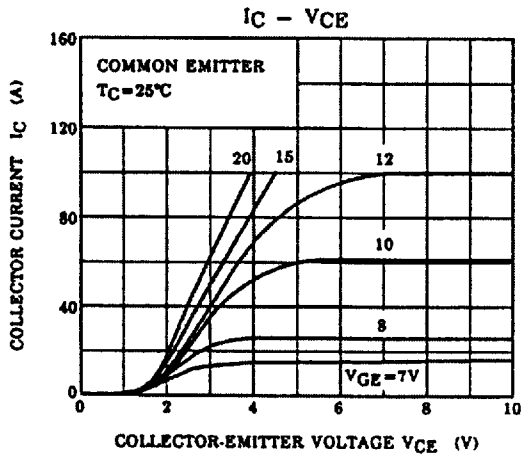

MIG50J901H

a. Inverter Stage

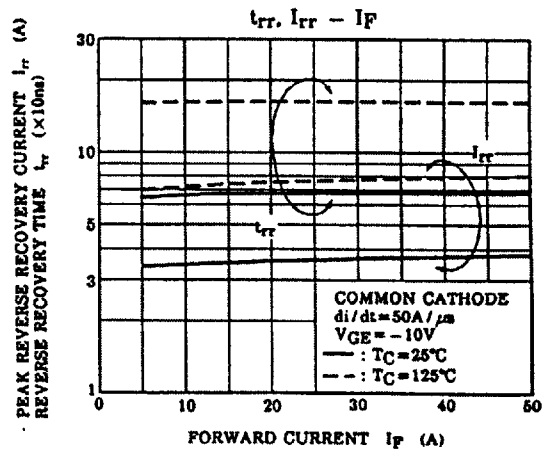
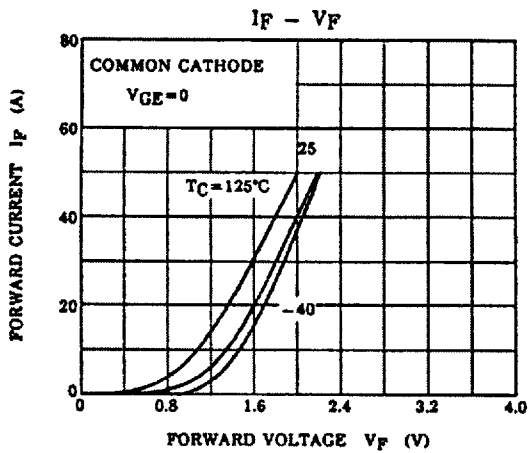
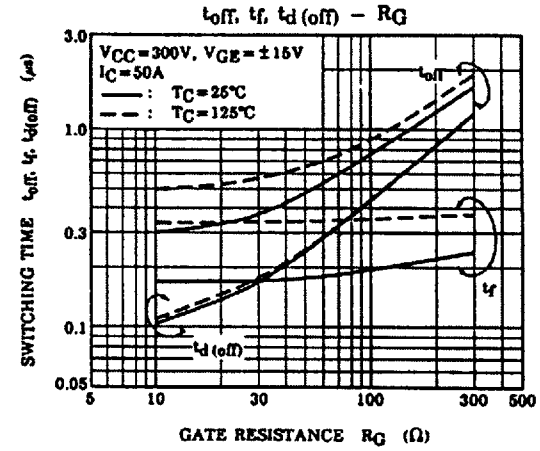
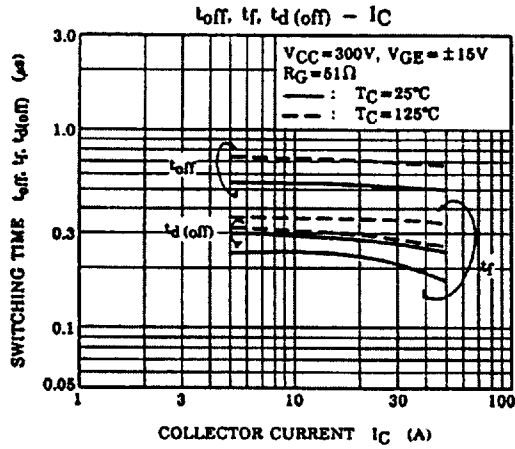
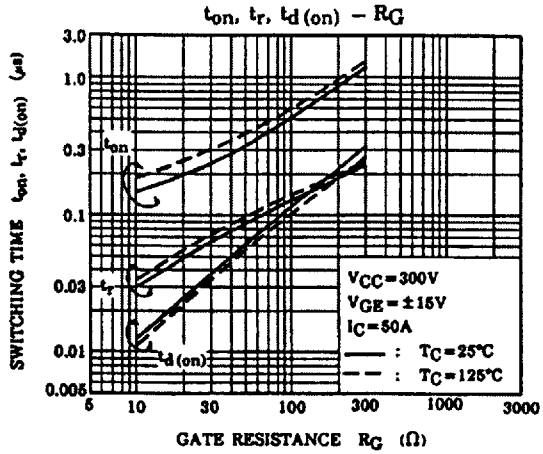
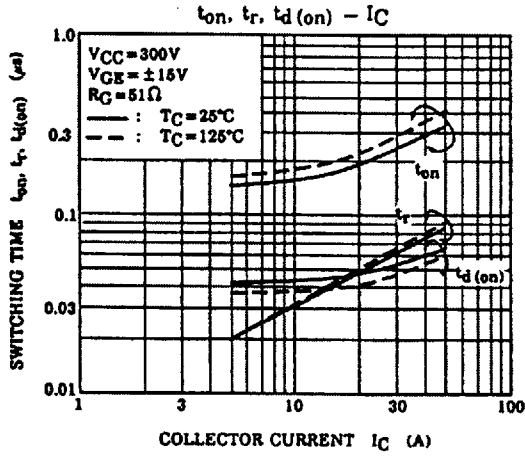

a. Inverter Stage

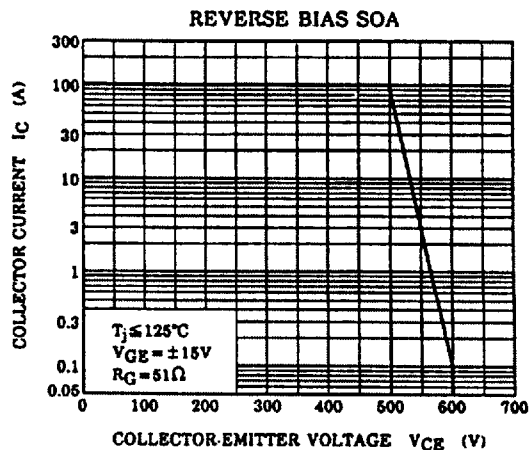
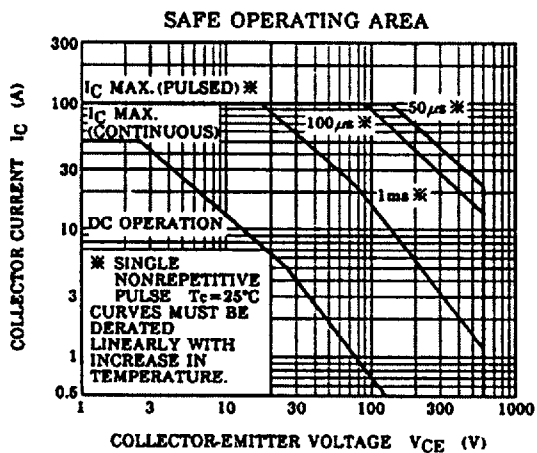
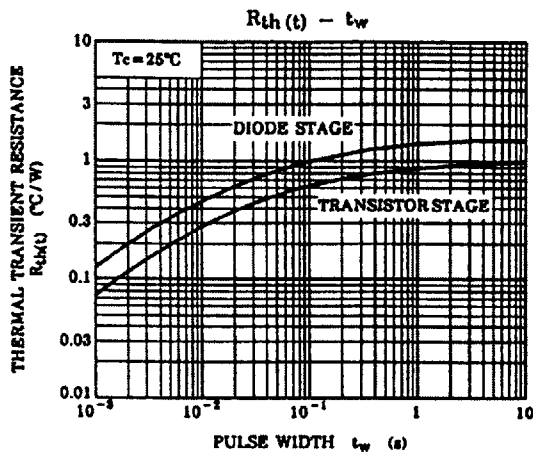
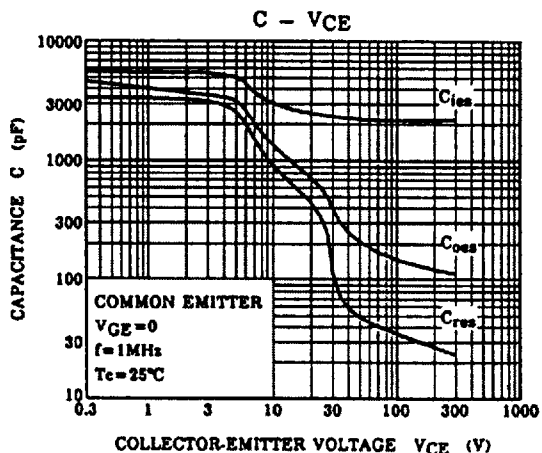

MIG50J901H

b. Converter Stage

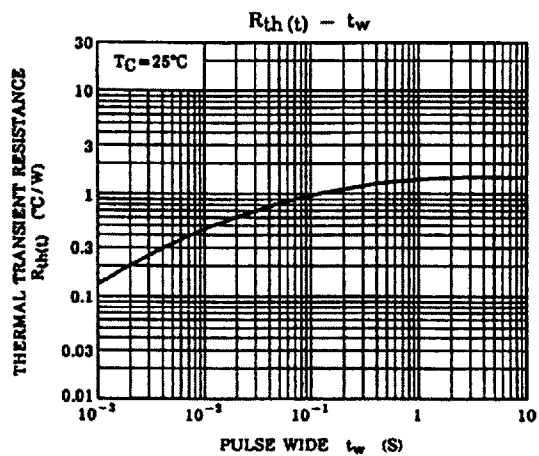
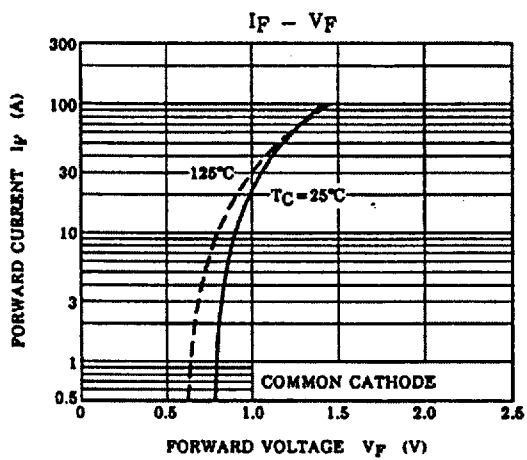

c. Brake Stage

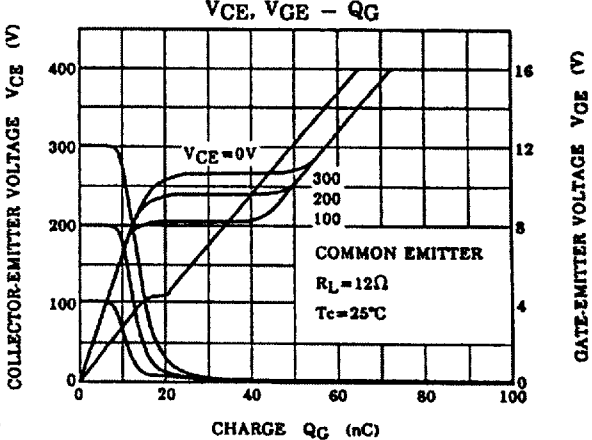
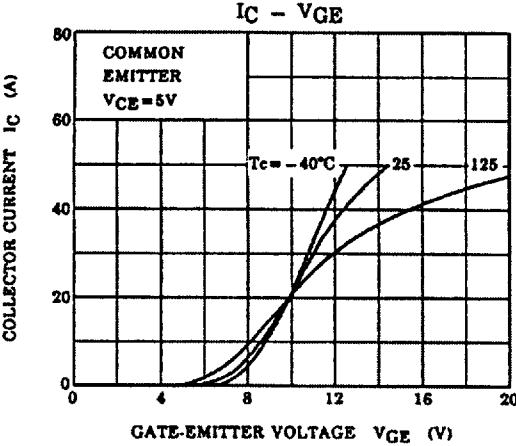
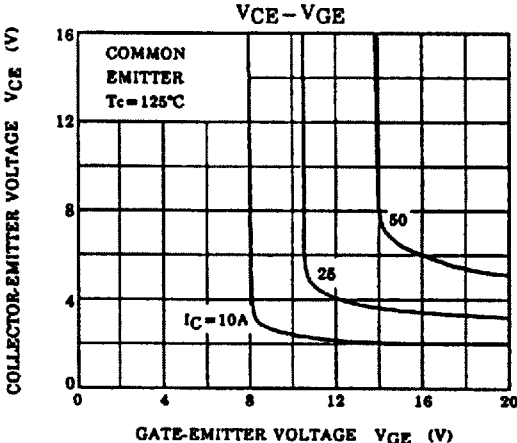
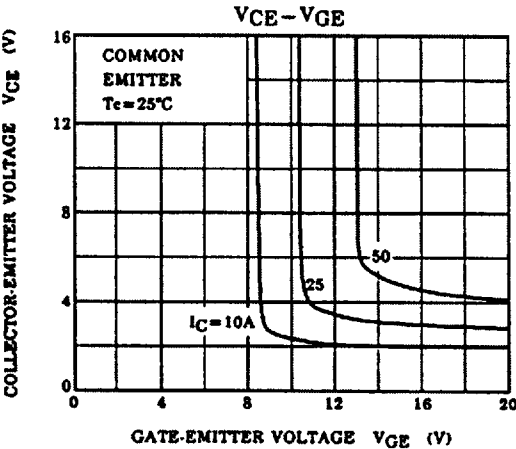
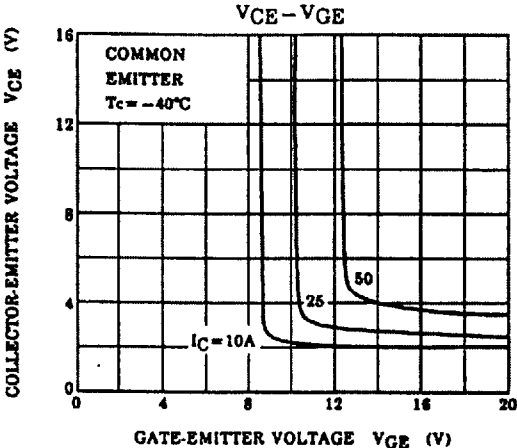
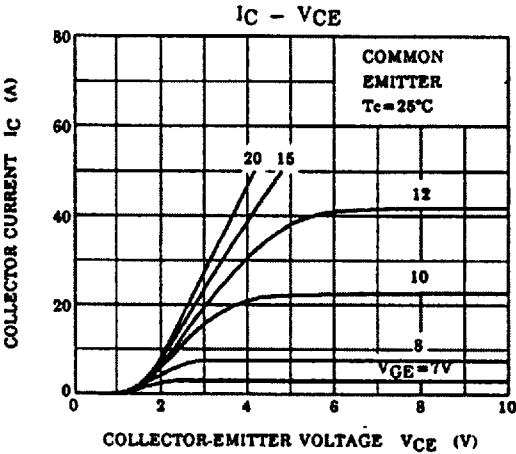

MIG50J901H

c. Brake Stage

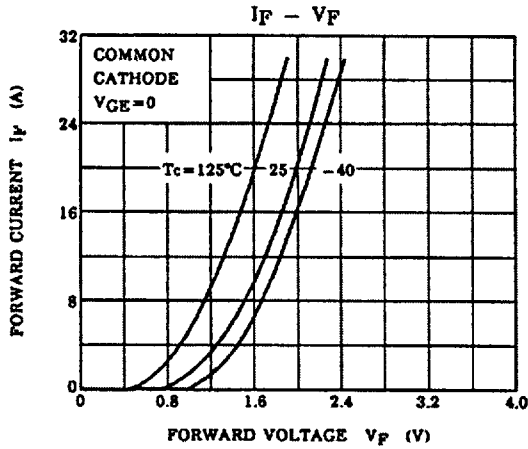
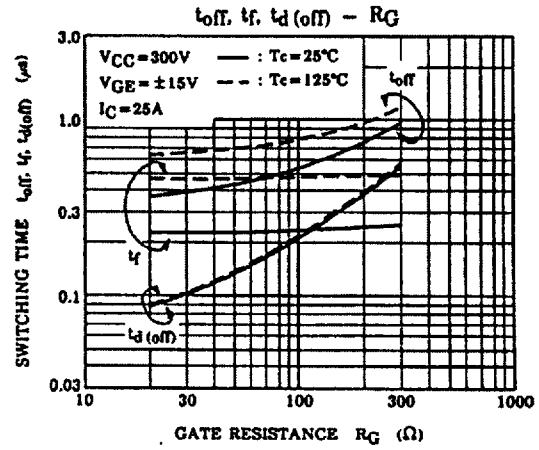
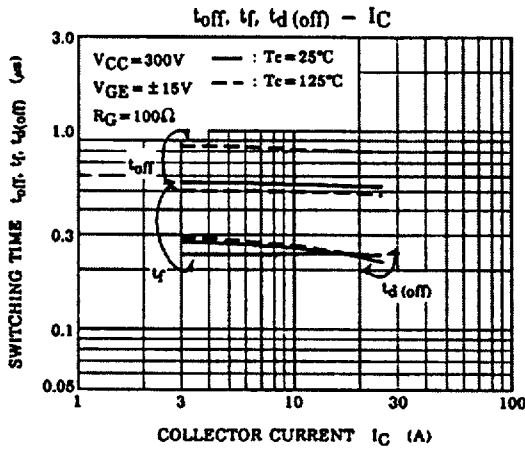
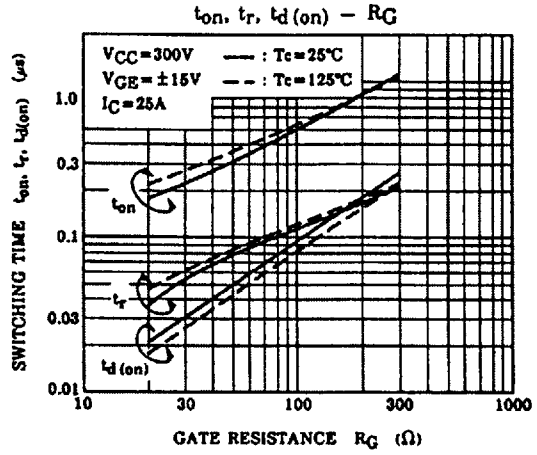
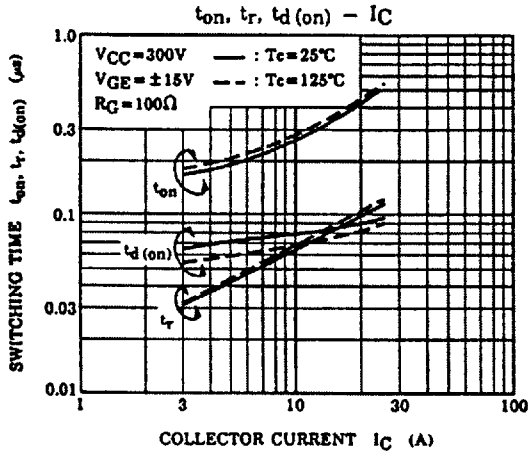

c. Brake Stage

